

2006 OFFSHORE RACING RULE CERTIFICATE™

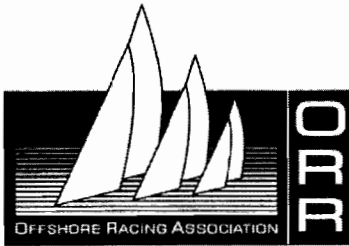

YACHT NAME: SIRENA
SAIL NUMBER: USA- 43990
ADDRESS: Mr Ron Wilson
 422 E Burgess St
 Pittsburgh, PA 15214-3303
ID: 322443N

Signature:

CERTIFICATE#: US41552 **AGE DATE:** 6/1/1983
ISSUED DATE: 6/13/2006 6:45:50 PM
YEAR VALID: 2006
CLASS: Wassa-Atlantic 51
BUILDER: WASSA
OFFSETS FILE: US41552.OFF **ABS PLAN:** Not filed
MEASUREMENT: FULL (Meters/Kilograms)
Freeboard Date: Sistership freeboards
Inclining Data: 5/30/2006
RIG TYPE: Sloop
SPNNAKER TYPE: Asym on a pole
KEEL TYPE: Fixed keel
PROP INSTALL: Strutdrive
PROP TYPE: Folding

LOA	15.41	DRAFT	1.982
Rated L	13.401	ECE	0.000
BMAX	3.31	Wet AREA	33.72
Stability Index	130.5	PIPA	0.0057
LPS	121.7	VCGD	0.000
CREW	995	VCGM	-0.062
Frbd Fwd M	1.220	RM2	160.7
Frbd Aft M	1.071	RM20	148.8
SG	1.002	RM40	131.1
SFFP	1.251	RM60	94.9
SAFP	14.100	RM90	45.1
DISP Meas	9183	MWT	0.0
Water Ballast	0	MCG	0.000

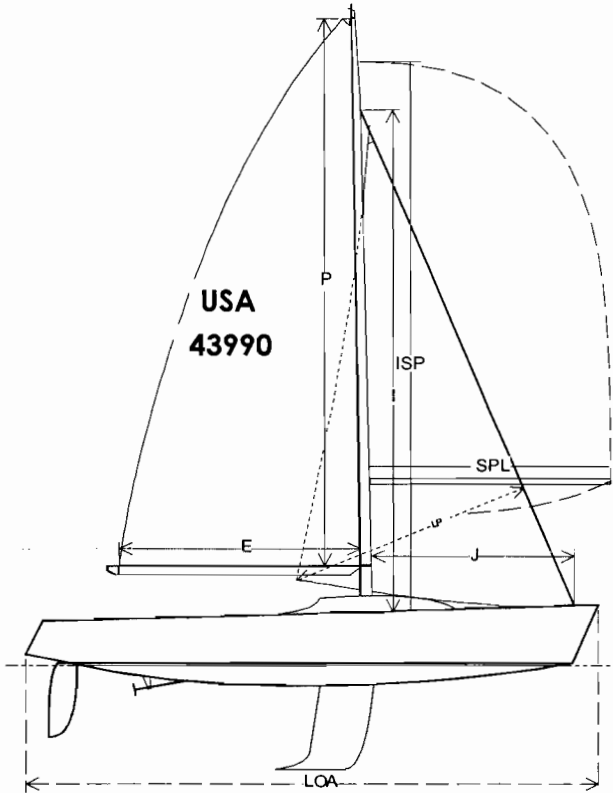

Genoa/Spinnakers		Mainsail Meas.		Mizzen Meas.	
IG	16.760	P	18.590	PY	0.000
ISP	16.770	E	6.400	EY	0.000
J	4.580	HB	0.184	HBY	0.000
LPGenoa	153 %	MGT	1.41	MGTY	0.00
FSP	0.072	MGU	2.44	MGUY	0.00
JLE	0.000	MGM	4.15	MGMY	0.00
JR	0.000	MGL	5.31	MGLY	0.00
SPL	5.320	MDT1	0.11	MDT1Y	0.00
SL	0.00	MDL1	0.20	MDL1Y	0.00
SMW	0.00	MDT2	0.10	MDT2Y	0.00
SF	0.00	MDL2	0.11	MDL2Y	0.00
ASL	16.86	TL	1.85	TLY	0.00
AMG	8.47	MSWgt	31.0	EB	0.00
ASF	7.95	A Main	70.8	YSD	0.0
A Genoa	61.3			YSF	0.0
A Sym	115.2			YSMG	0.0
A Asym	117.6			A Mizzen	0.0

TABLE OF RATINGS	Time-on-Time (TOT)	6kt	8kt	10kt	12kt	16kt	20kt	24kt	A	B
		GPH: 563.5								
CLOSED COURSE:	0.996	668.0	563.9	510.7	478.5	443.7	425.3	414.9	1.09418	190.95
WW 60%, LW 40%:	0.974	921.6	765.3	680.7	627.5	571.9	549.4	539.9	0.93970	155.64
WW 50%, LW 50%:	0.976	919.3	759.1	670.5	613.5	552.3	525.0	510.3	0.90320	126.81
Ocean Course:	1.045	858.5	666.8	558.4	487.7	413.8	377.3	353.4	0.83384	54.07
Ocean Non-Spin:	0.989	916.5	707.7	590.2	514.4	436.1	398.5	375.2	0.78338	51.54
Offshore Offwind:	0.986	804.9	647.0	559.2	504.4	438.5	397.0	365.5	0.90848	110.19

Chicago-Mackinac All-Purpose TOT: 0.983 **Chicago-Mackinac Offwind TOT: 0.986**

ET = Elapsed Time CT = Corrected Time
 Time on Distance Scoring: CT = ET - (Rating - Rating Scratch Boat) x Distance
 Time on Time Scoring: CT = TOT x ET
 Performance Line Scoring: CT = (A x ET) - (B x Distance)

